

System Specifications

Model: R-301

Frequency: 2.4GHz FHSS

Operating Voltage: 6.0~8.4V (Alkaline/Ni-Cd/Ni-MH)
7.4~11.1V (Li-poly3S)

Mechanical Speed Control Setup

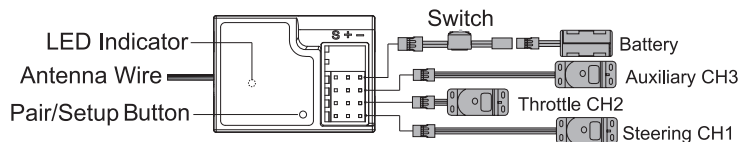

Electronic Speed Control Setup

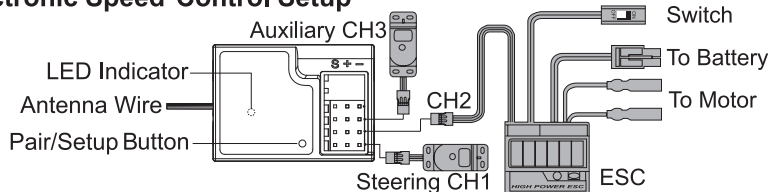

-30 & -30 Bind



T-301



R-301



R-301

Power off the transmitter. Press and hold the binding button on the receiver, in the meantime, turn the receiver on, the LED flashes quickly, loosen the button.

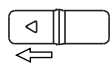

T-301

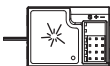

R-301

Turn the transmitter on, it will bind with the receiver automatically. If the LED indicator on the receiver becomes and stays continuously lit, the binding is successfully setup.



The receiver can only receive the signals transmitted by the transmitter once they are in successfully binding. Generally the two of them have been paired before leaving the factory, please check before use. If not, users can setup the binding according to the following steps.



If the LED light is flashing or OFF, the setup failed. Please shorten the distance between the transmitter and the receiver, bind again. Long binding distance can cause setup failure, so please do not keep the receiver far away from the transmitter.

Fail-Safe setup procedure

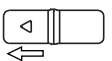

T-301



R-301



R-301

Turn on the power switches of both the transmitter and receiver, the LED indicator lights should both be on.



T-301
CH2

Press and hold the receiver setup button for 2 seconds, the LED rapid flash, in 5 seconds, put CH2 in the brake condition and hold it until the LED continuously lit.



Please note transmitter must be paired with receiver before setting up the S/F mode. The model car has been preset at a F/S mode to be automatically braked after running out of control. Check before use whether the F/S mode still works. If not, follow these steps to reset.



Any new binding of the transmitter and receiver should clear the preset fail-safe.

Receiver's Antenna Installation

The wave length of the 2.4GHz is much shorter than that of the conventional frequencies, it is very susceptible to loss of signal which results in a receiving error.

To obtain the best results, please refer to the following instructions;

1. The antenna must be kept as straight as possible. Otherwise it will reduce the effective range.
2. The antenna should be perpendicular to the model. Larger models can have large metal objects that can attenuate the RF signal. In this case the antennas should be placed at sides of the model. Then the best RF signal condition is obtained at any attitude.
3. The antennas must be kept away from conductive materials, such as metal and carbon by at least a half inch. The coaxial part of the antennas does not need to follow these guidelines, but do not bend it in a small radius.
4. Keep the antennas away from the motor, ESC, and other noise sources as much as possible.

*The main purpose of the photo demonstrates how the antenna should be placed. For actual installation the receiver must be wrapped with a sponge or placed with floating material to protect it from vibration.

The receiver contains precision electronic parts. It is the most delicate radio component on-board the model and should be protected from vibration, shock and temperature extremes. To protect the receiver, wrap it in R/C foam rubber or other vibration-absorbing material. If appropriate, waterproof the receiver by placing it in a plastic bag and closing the open end with a rubber band before wrapping it in foam. If moisture enters the receiver, intermittent operation or a failure may result. Wrapping the receiver in a plastic bag also protects it from fuel and exhaust residue which, in some models, can work its way into the model.

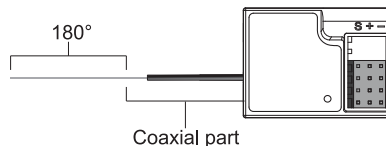

Antenna





DIGITAL PROPORTIONAL SYSTEM

2.4GHZ T-301

Transmitter T-301 Operating Instructions

System Specifications

Model: **T-301**

Output Power: <100mW

Operating Voltage: 4.8 or 6V

Power Supply: 4 Cell Alkaline/Ni-Cd/Ni-MH

Frequency/Modulation Type: 2.4GHz FHSS

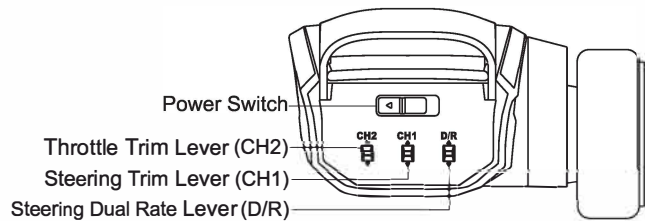
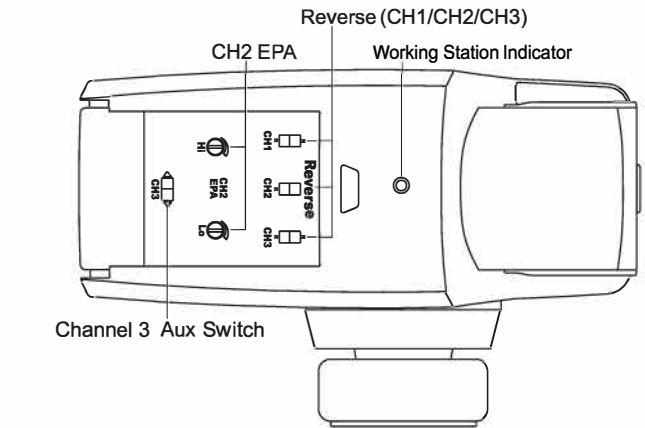
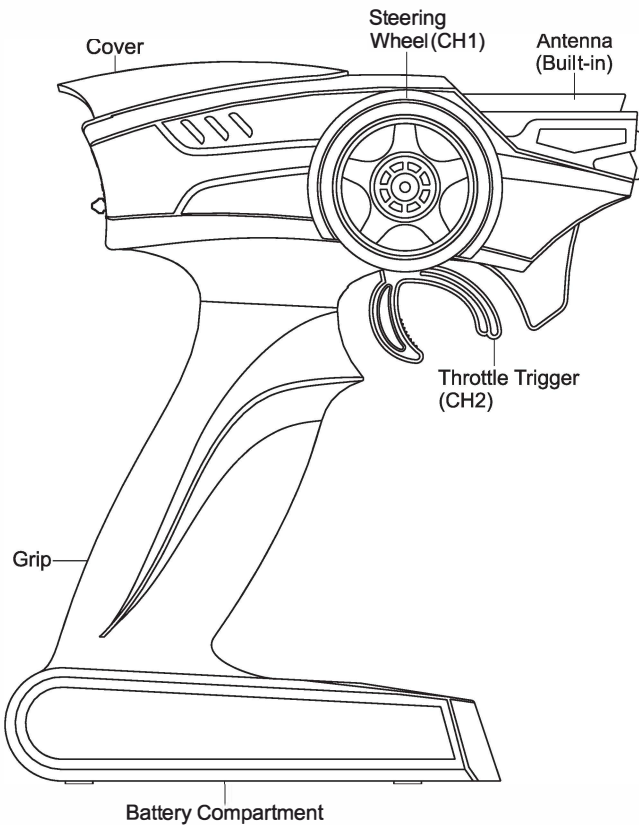

Installing the Transmitter Batteries



Open the battery holding tray. Insert 4 AA batteries into the marked spaces. Please note the correct direction of the batteries.

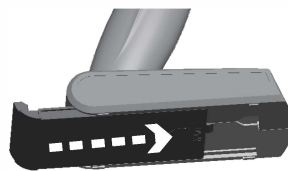

Incorrect battery insertion could damage the transmitter. This 2.4Ghz transmitter has an internal Antenna.

Installing the battery pack



You need to insert the battery pack in the open section for the battery. Use the chassis cut-out for corner wiring if needed. Use the straps provided to secure the battery in place.

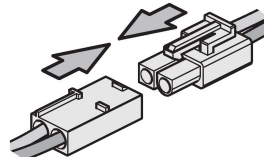

Once fastened and secured please connect the battery plug into the speed controller plug noting correct polarity. Red to red, black to black.

CH1(Steering)Trim

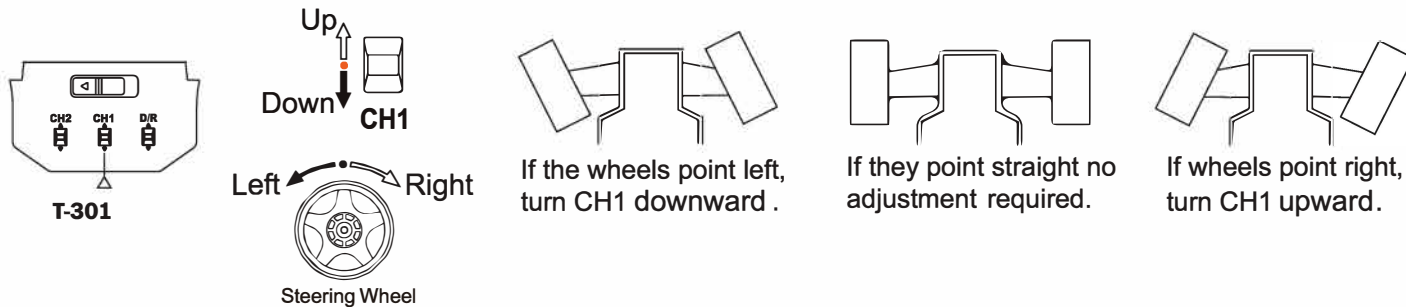

CH1(Steering Dual-Rate)D/R

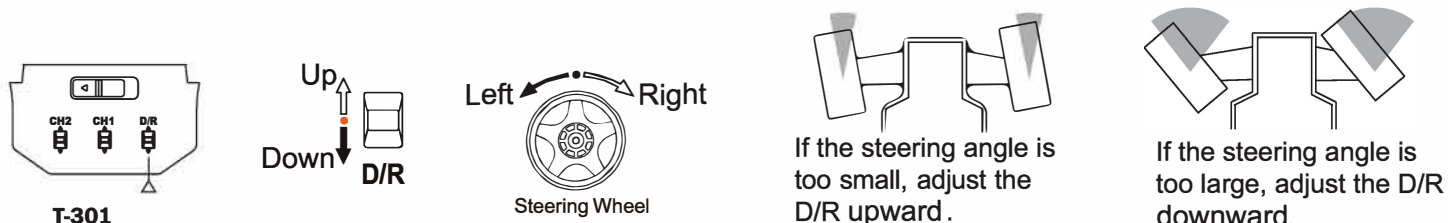

CH2(Throttle) Trim

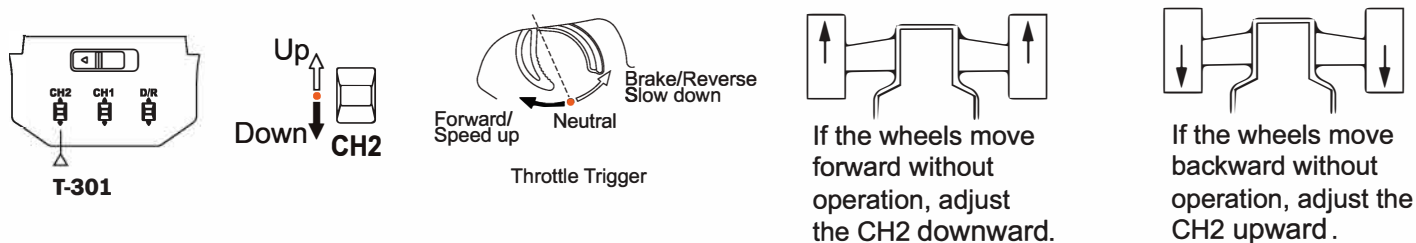

CH1(Steering Reverse)

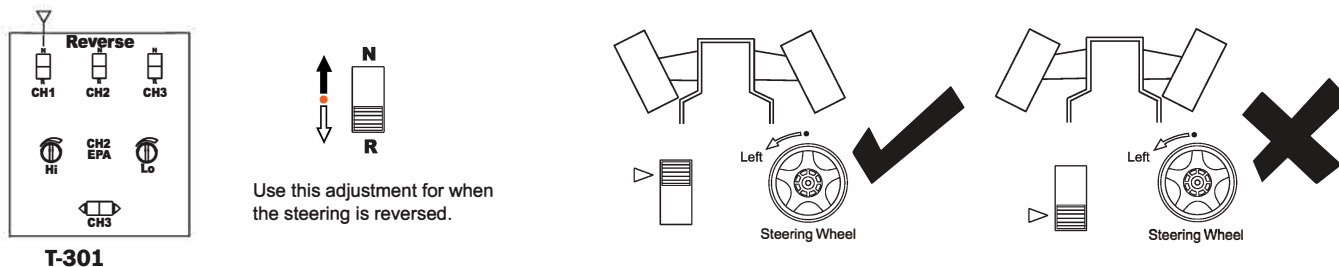

CH2(Throttle Reverse)

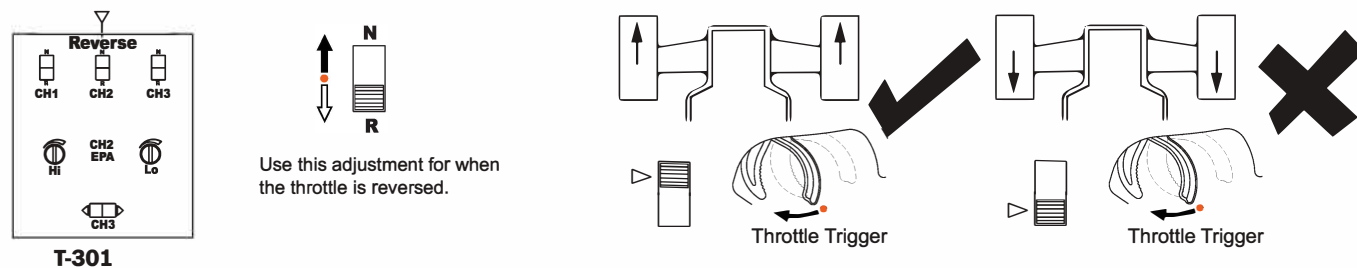

CH2(Throttle end point)

