

TEST REPORT

Application No.: SZCR2401000257AT
Applicant: Shantou City Youjie Technology Co., Ltd.
Address of Applicant: Shangxindong Road, Shangcun, Lianxia Town, Chenghai District, Shantou City
Manufacturer: Shantou City Youjie Technology Co., Ltd.
Address of Manufacturer: Shangxindong Road, Shangcun, Lianxia Town, Chenghai District, Shantou City
Equipment Under Test (EUT):
EUT Name: REMOTE CONTROL CAR SERIES
Model No.: UJ99-P220, UJ99-P221, UJ99-P222, UJ99-P223, UJ99-Y240, UJ99-Y241, UJ99-Y242, UJ99-Y243, UJ99-T200, UJ99-T201, UJ99-T202, UJ99-T203, UJ99-F160, UJ99-F161, UJ99-F162, UJ99-F163, UJ99-F120, UJ99-F121, UJ99-F122, UJ99-F123, UJ99-Y200, UJ99-Y201, UJ99-Y202, UJ99-Y203 ♣
♣ Please refer to section 2 of this report which indicates which model was actually tested and which were electrically identical.
Standard(s) : EN 300 220-1 V3.1.1
EN 300 220-2 V3.2.1
Date of Receipt: 2023-04-23 (for original report SZCR230400117602R1)
Date of Test: 2023-04-25 to 2023-05-05 (for original report SZCR230400117602R1)
Date of Issue: 2023-06-19 (for original report SZCR230400117602R1)
2024-01-22 (for new report SZCR240100025702)

Test Result:	Pass*
---------------------	--------------

* In the configuration tested, the EUT complied with the standards specified above.

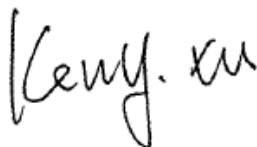

Keny Xu
EMC Laboratory Manager



Unless otherwise agreed in writing, this document is issued by the Company subject to its General Conditions of Service printed overleaf, available on request or accessible at <https://www.sgs.com/en/Terms-and-Conditions>. Attention is drawn to the limitation of liability, indemnification and jurisdiction issues defined therein. Any holder of this document is advised that information contained hereon reflects the Company's findings at the time of its intervention only and within the limits of Client's instructions, if any. The Company's sole responsibility is to its Client and this document does not exonerate parties to a transaction from exercising all their rights and obligations under the transaction documents. This document cannot be reproduced except in full, without prior written approval of the Company. Any unauthorized alteration, forgery or falsification of the content or appearance of this document is unlawful and offenders may be prosecuted to the fullest extent of the law. Unless otherwise stated the results shown in this test report refer only to the sample(s) tested and such sample(s) are retained for 30 days only.
Attention: To check the authenticity of testing /inspection report & certificate, please contact us at telephone: (86-755) 8307 1443, or email: CN.Doccheck@sgs.com
No.1 Workshop, M-10, Middle Section, Science & Technology Park, Nanshan District, Shenzhen, Guangdong, China 518057 t (86-755) 26012053 f (86-755) 26710594 www.sgsgroup.com.cn
中国·广东·深圳市南山区科技园中区M-10栋1号厂房 邮编: 518057 t (86-755) 26012053 f (86-755) 26710594 sgs.china@sgs.com

SGS-CSTC Standards Technical Services Co., Ltd. Shenzhen Branch

SZEMC-TRF-01 Rev. A/0 Aug01,2022

Report No.: SZCR240100025702

Page: 2 of 39

Revision Record				
Version	Chapter	Date	Modifier	Remark
01		2024-01-22		Original

Authorized for issue by:				
		<i>Martin Tang</i>		

		Martin Tang/Project Engineer		
		<i>Eric Fu</i>		

		Eric Fu/Reviewer		



SGS-CSTC Standards Technical Services Co., Ltd.
Shenzhen Branch

Unless otherwise agreed in writing, this document is issued by the Company subject to its General Conditions of Service printed overleaf, available on request or accessible at <https://www.sgs.com/en/Terms-and-Conditions>. Attention is drawn to the limitation of liability, indemnification and jurisdiction issues defined therein. Any holder of this document is advised that information contained hereon reflects the Company's findings at the time of its intervention only and within the limits of Client's instructions, if any. The Company's sole responsibility is to its Client and this document does not exonerate parties to a transaction from exercising all their rights and obligations under the transaction documents. This document cannot be reproduced except in full, without prior written approval of the Company. Any unauthorized alteration, forgery or falsification of the content or appearance of this document is unlawful and offenders may be prosecuted to the fullest extent of the law. Unless otherwise stated the results shown in this test report refer only to the sample(s) tested and such sample(s) are retained for 30 days only.

Attention: To check the authenticity of testing /inspection report & certificate, please contact us at telephone: (86-755) 8307 1443, or email: CN.Doccheck@sgs.com
 No.1 Workshop, M-10, Middle Section, Science & Technology Park, Nanshan District, Shenzhen, Guangdong, China 518057 t (86-755) 26012053 f (86-755) 26710594 www.sgs.com.cn
 中国·广东·深圳市南山区科技园中区M-10栋1号厂房 邮编: 518057 t (86-755) 26012053 f (86-755) 26710594 sgs.china@sgs.com

2 Test Summary

Radio Spectrum Matter Part				
Item	Standard	Method	Requirement	Result
Operating frequency	EN 300 220-2 V3.2.1	EN 300 220-1 V3.1.1 clause 5.1.2	EN 300 220-2 V3.2.1 clause 4.2.1	Pass
Unwanted emissions in the spurious domain		EN 300 220-1 V3.1.1 clause 5.9.3	EN 300 220-2 V3.2.1 clause 4.2.2	Pass
Effective Radiated Power		EN 300 220-1 V3.1.1 clause 5.2.2	EN 300 220-2 V3.2.1 clause 4.3.1	Pass
Duty Cycle		EN 300 220-1 V3.1.1 clause 5.4.2	EN 300 220-2 V3.2.1 clause 4.3.3	Pass
Occupied Bandwidth		EN 300 220-1 V3.1.1 clause 5.6.3	EN 300 220-2 V3.2.1 clause 4.3.4	Pass
Transient power		EN 300 220-1 V3.1.1 clause 5.10.3	EN 300 220-2 V3.2.1 clause 4.3.6	Pass
Adjacent Channel Power		EN 300 220-1 V3.1.1 clause 5.11.3	EN 300 220-2 V3.2.1 clause 4.3.7	Pass
TX behaviour under Low Voltage Conditions		EN 300 220-1 V3.1.1 clause 5.12.3	EN 300 220-2 V3.2.1 clause 4.3.8	Pass
Blocking		EN 300 220-1 V3.1.1 clause 5.18.6	EN 300 220-2 V3.2.1 clause 4.4.2	Pass

Declaration of EUT Family Grouping:

Original model No. in report SZCR230400117602R1 UJ99-P220, UJ99-P221, UJ99-P222, UJ99-P223, UJ99-Y240, UJ99-Y241, UJ99-Y242, UJ99-Y243, UJ99-T200, UJ99-T201, UJ99-T202, UJ99-T203, UJ99-F160, UJ99-F161, UJ99-F162, UJ99-F163, UJ99-F120, UJ99-F121, UJ99-F122, UJ99-F123

Only the model UJ99-P220 was tested in original report SZCR230400117602R1, since according to the declaration from the applicant, the electrical circuit design, PCB layout, components used and internal wiring and functions were identical for the above models, with only difference on color, appearance and package.

New model No. in report SZCR240100025702: UJ99-P220, UJ99-P221, UJ99-P222, UJ99-P223, UJ99-Y240, UJ99-Y241, UJ99-Y242, UJ99-Y243, UJ99-T200, UJ99-T201, UJ99-T202, UJ99-T203, UJ99-F160, UJ99-F161, UJ99-F162, UJ99-F163, UJ99-F120, UJ99-F121, UJ99-F122, UJ99-F123, UJ99-Y200, UJ99-Y201, UJ99-Y202, UJ99-Y203

This report was an additional report copied from the report SZCR230400117602R1, just added the model No. and photo. Since the electrical circuit design, layout, components used and internal wiring for the models in the original report SZCR230400117602R1 were exactly the same as the models in this report, only different on model No., color, appearance and package.

Therefore original data were kept in this report.



Unless otherwise agreed in writing, this document is issued by the Company subject to its General Conditions of Service printed overleaf, available on request or accessible at <https://www.sgs.com/en/Terms-and-Conditions>. Attention is drawn to the limitation of liability, indemnification and jurisdiction issues defined therein. Any holder of this document is advised that information contained hereon reflects the Company's findings at the time of its intervention only and within the limits of Client's instructions, if any. The Company's sole responsibility is to its Client and this document does not exonerate parties to a transaction from exercising all their rights and obligations under the transaction documents. This document cannot be reproduced except in full, without prior written approval of the Company. Any unauthorized alteration, forgery or falsification of the content or appearance of this document is unlawful and offenders may be prosecuted to the fullest extent of the law. Unless otherwise stated the results shown in this test report refer only to the sample(s) tested and such sample(s) are retained for 30 days only.
Attention: To check the authenticity of testing /inspection report & certificate, please contact us at telephone: (86-755) 8307 1443, or email: CN.Doccheck@sgs.com
 No.1 Workshop, M-10, Middle Section, Science & Technology Park, Nanshan District, Shenzhen, Guangdong, China 518057 t (86-755) 26012053 f (86-755) 26710594 www.sgs.com.cn
 中国·广东·深圳市南山区科技园中区M-10栋1号厂房 邮编: 518057 t (86-755) 26012053 f (86-755) 26710594 sgs.china@sgs.com

3 Contents

	Page
1 Cover Page	1
2 Test Summary	3
3 Contents.....	4
4 General Information.....	6
4.1 Details of E.U.T.	6
4.2 Environment Parameter.....	6
4.3 Description of Support Units.....	7
4.4 Measurement Uncertainty	7
4.5 Test Location	8
4.6 Test Facility	8
4.7 Deviation from Standards.....	8
4.8 Abnormalities from Standard Conditions	8
5 Equipment List.....	9
6 Radio Spectrum Matter Test Results	12
6.1 Operating frequency	12
6.1.1 E.U.T. Operation	12
6.1.2 Test Mode Description	12
6.1.3 Test Setup Diagram	12
6.1.4 Measurement Procedure and Data.....	12
6.2 Unwanted emissions in the spurious domain	13
6.2.1 E.U.T. Operation	13
6.2.2 Test Mode Description	13
6.2.3 Test Setup Diagram	14
6.2.4 Measurement Procedure and Data.....	15
6.3 Effective Radiated Power	17
6.3.1 E.U.T. Operation	18
6.3.2 Test Mode Description	18
6.3.3 Test Setup Diagram	18
6.3.4 Measurement Procedure and Data.....	19
6.4 Duty Cycle	20
6.5 Occupied Bandwidth.....	21
6.5.1 E.U.T. Operation	22
6.5.2 Test Mode Description	22
6.5.3 Test Setup Diagram	22
6.5.4 Measurement Procedure and Data.....	23
6.6 Transient power.....	24
6.6.1 E.U.T. Operation	24
6.6.2 Test Mode Description	24
6.6.3 Test Setup Diagram	25



6.6.4	Measurement Procedure and Data	25
6.7	Adjacent Channel Power	26
6.7.1	E.U.T. Operation	26
6.7.2	Test Mode Description	26
6.7.3	Test Setup Diagram	27
6.7.4	Measurement Procedure and Data	27
6.8	TX behaviour under Low Voltage Conditions	28
6.8.1	E.U.T. Operation	28
6.8.2	Test Mode Description	28
6.8.3	Test Setup Diagram	29
6.8.4	Measurement Procedure and Data	29
6.9	Blocking	30
6.9.1	E.U.T. Operation	31
6.9.2	Test Mode Description	31
6.9.3	Test Setup Diagram	31
6.9.4	Measurement Procedure and Data	32
7	Test Setup Photo.....	33
8	EUT Constructional Details (EUT Photos).....	34
9	Appendix.....	35



4 General Information

4.1 Details of E.U.T.

Power supply:	3V DC(1.5V x 2 "AA" Size Batteries) for TX 4.5V DC(1.5V x 3 "AA" Size Batteries) for RX
Operation Frequency:	27.145MHz
Sample Type:	Portable production
Antenna Type:	Integral
Antenna Gain:	0dBi
Receiver category:	2

Remark: The information in this section is provided by the applicant or manufacturer, SGS is not liable to the accuracy, suitability, reliability or/and integrity of the information.

4.2 Environment Parameter

Environment Parameter	Selected Values During Tests	
Relative Humidity	Ambient	
Value	Temperature(°C)	Voltage(V)
Normal Temperature & Normal Voltage	24	3
Low Extreme Test Temperature & Low Extreme Test Voltage	0	2.55
High Extreme Test Temperature & Low Extreme Test Voltage	45	2.55
Low Extreme Test Temperature & High Extreme Test Voltage	0	3
High Extreme Test Temperature & High Extreme Test Voltage	45	3



Unless otherwise agreed in writing, this document is issued by the Company subject to its General Conditions of Service printed overleaf, available on request or accessible at <https://www.sgs.com/en/Terms-and-Conditions>. Attention is drawn to the limitation of liability, indemnification and jurisdiction issues defined therein. Any holder of this document is advised that information contained hereon reflects the Company's findings at the time of its intervention only and within the limits of Client's instructions, if any. The Company's sole responsibility is to its Client and this document does not exonerate parties to a transaction from exercising all their rights and obligations under the transaction documents. This document cannot be reproduced except in full, without prior written approval of the Company. Any unauthorized alteration, forgery or falsification of the content or appearance of this document is unlawful and offenders may be prosecuted to the fullest extent of the law. Unless otherwise stated the results shown in this test report refer only to the sample(s) tested and such sample(s) are retained for 30 days only.

Attention: To check the authenticity of testing /inspection report & certificate, please contact us at telephone: (86-755) 8307 1443, or email: CN.Doccheck@sgs.com

No.1 Workshop, M-10, Middle Section, Science & Technology Park, Nanshan District, Shenzhen, Guangdong, China 518057 t (86-755) 26012053 f (86-755) 26710594 www.sgs.com.cn
 中国·广东·深圳市南山区科技园中区M-10栋1号厂房 邮编: 518057 t (86-755) 26012053 f (86-755) 26710594 sgs.china@sgs.com

4.3 Description of Support Units

Description	Manufacturer	Model No.	Serial No.
--	--	--	--
The EUT has been tested as an independent unit.			

4.4 Measurement Uncertainty

Test Item	Measurement Uncertainty
Operating frequency	± 7.25E-8
Unwanted emissions in the spurious domain	± 4.5dB
Effective Radiated Power	± 4.5dB
Occupied Bandwidth	± 7.25E-8
Transient power	± 0.75dB
Adjacent Channel Power	± 0.75dB
TX behaviour under Low Voltage Conditions	± 7.25E-8
Blocking	± 0.75dB

Remark:

The U_{lab} (lab Uncertainty) is less than $U_{CISPR/ETSI}$ (CISPR/ETSI Uncertainty), so the test results
 – compliance is deemed to occur if no measured disturbance level exceeds the disturbance limit;
 – non-compliance is deemed to occur if any measured disturbance level exceeds the disturbance limit.



Unless otherwise agreed in writing, this document is issued by the Company subject to its General Conditions of Service printed overleaf, available on request or accessible at <https://www.sgs.com/en/Terms-and-Conditions>. Attention is drawn to the limitation of liability, indemnification and jurisdiction issues defined therein. Any holder of this document is advised that information contained hereon reflects the Company's findings at the time of its intervention only and within the limits of Client's instructions, if any. The Company's sole responsibility is to its Client and this document does not exonerate parties to a transaction from exercising all their rights and obligations under the transaction documents. This document cannot be reproduced except in full, without prior written approval of the Company. Any unauthorized alteration, forgery or falsification of the content or appearance of this document is unlawful and offenders may be prosecuted to the fullest extent of the law. Unless otherwise stated the results shown in this test report refer only to the sample(s) tested and such sample(s) are retained for 30 days only.

Attention: To check the authenticity of testing /inspection report & certificate, please contact us at telephone: (86-755) 8307 1443, or email: CN.Doccheck@sgs.com

No.1 Workshop, M-10, Middle Section, Science & Technology Park, Nanshan District, Shenzhen, Guangdong, China 518057 t (86-755) 26012053 f (86-755) 26710594 www.sgsgroup.com.cn
 中国·广东·深圳市南山区科技园中区M-10栋1号厂房 邮编: 518057 t (86-755) 26012053 f (86-755) 26710594 sgs.china@sgs.com

4.5 Test Location

All tests were performed at:

SGS-CSTC Standards Technical Services Co., Ltd., Shenzhen Branch

No. 1 Workshop, M-10, Middle Section, Science & Technology Park, Nanshan District, Shenzhen, Guangdong, China. 518057.

Tel: +86 755 2601 2053 Fax: +86 755 2671 0594

No tests were sub-contracted.

4.6 Test Facility

The test facility is recognized, certified, or accredited by the following organizations:

• A2LA (Certificate No. 3816.01)

SGS-CSTC Standards Technical Services Co., Ltd., Shenzhen EMC Laboratory is accredited by the American Association for Laboratory Accreditation(A2LA). Certificate No. 3816.01.

• VCCI (Member No. 1937)

The 3m Fully-anechoic chamber for above 1GHz, 10m Semi-anechoic chamber for below 1GHz, Shielded Room for Mains Port Conducted Interference Measurement and Telecommunication Port Conducted Interference Measurement of SGS-CSTC Standards Technical Services Co., Ltd. Shenzhen EMC laboratory have been registered in accordance with the Regulations for Voluntary Control Measures with Registration No.: G-20026, R-14188, C-12383 and T-11153 respectively.

• FCC –Designation Number: CN1336

SGS-CSTC Standards Technical Services Co., Ltd., Shenzhen EMC Laboratory has been recognized as an accredited testing laboratory.

Designation Number: CN1336. Test Firm Registration Number: 787754.

• Innovation, Science and Economic Development Canada

SGS-CSTC Standards Technical Services Co., Ltd., Shenzhen EMC Laboratory has been recognized by ISED as an accredited testing laboratory.

CAB identifier: CN0006.

IC#: 4620C.

4.7 Deviation from Standards

None

4.8 Abnormalities from Standard Conditions

None



Unless otherwise agreed in writing, this document is issued by the Company subject to its General Conditions of Service printed overleaf, available on request or accessible at <https://www.sgs.com/en/Terms-and-Conditions>. Attention is drawn to the limitation of liability, indemnification and jurisdiction issues defined therein. Any holder of this document is advised that information contained hereon reflects the Company's findings at the time of its intervention only and within the limits of Client's instructions, if any. The Company's sole responsibility is to its Client and this document does not exonerate parties to a transaction from exercising all their rights and obligations under the transaction documents. This document cannot be reproduced except in full, without prior written approval of the Company. Any unauthorized alteration, forgery or falsification of the content or appearance of this document is unlawful and offenders may be prosecuted to the fullest extent of the law. Unless otherwise stated the results shown in this test report refer only to the sample(s) tested and such sample(s) are retained for 30 days only.

Attention: To check the authenticity of testing /inspection report & certificate, please contact us at telephone: (86-755) 8307 1443, or email: CN.Doccheck@sgs.com

5 Equipment List

Operating frequency					
Equipment	Manufacturer	Model No.	Inventory No.	Cal Date	Cal Due Date
DC Power Supply	Chroma	62012P-80-60	SEM011-11	2022-10-20	2023-10-19
MXA Signal Analyzer	KEYSIGHT	N9020A	SEM004-19	2023-03-21	2024-03-20
Signal Generator	KEYSIGHT	N5173B	SEM006-05	2022-09-29	2023-09-28
Measurement Software	TST PASS	TST PASS V2.0	N/A	N/A	N/A
Coaxial Cable	SGS	N/A	SEM031-01	2022-07-08	2023-07-07
Attenuator	Huber+Suhner	6620_SMA-50-1	SEM021-09	2023-03-31	2024-03-30
Programmable Temperature & Humidity Chamber	Votsch Industrietechnik GmbH	VT 4002	SEM002-15	2023-03-21	2024-03-20

Unwanted emissions in the spurious domain					
Equipment	Manufacturer	Model No.	Inventory No.	Cal Date	Cal Due Date
3m Semi-Anechoic Chamber	ETS-LINDGREN	N/A	SEM001-01	2020-07-19	2023-07-18
MXE EMI Receiver	Agilent Technologies	N9038A	SEM004-15	2022-10-20	2023-10-19
BiConiLog Antenna	ETS-LINDGREN	3142C	SEM003-01	2021-09-17	2023-09-16
Pre-Amplifier	Agilent Technologies	8447D	SEM005-01	2023-03-20	2024-03-19
Measurement Software	AUDIX	e3 V8.2014-6-27	N/A	N/A	N/A
Coaxial Cable	SGS	N/A	SEM025-01	2022-07-08	2023-07-07

Effective Radiated Power					
Equipment	Manufacturer	Model No.	Inventory No.	Cal Date	Cal Due Date
3m Semi-Anechoic Chamber	ETS-LINDGREN	N/A	SEM001-01	2020-07-19	2023-07-18
MXE EMI Receiver	Agilent Technologies	N9038A	SEM004-15	2022-10-20	2023-10-19
BiConiLog Antenna	ETS-LINDGREN	3142C	SEM003-01	2021-09-17	2023-09-16
Pre-Amplifier	Agilent Technologies	8447D	SEM005-01	2023-03-20	2024-03-19
Measurement Software	AUDIX	e3 V8.2014-6-27	N/A	N/A	N/A
Coaxial Cable	SGS	N/A	SEM025-01	2022-07-08	2023-07-07



Unless otherwise agreed in writing, this document is issued by the Company subject to its General Conditions of Service printed overleaf, available on request or accessible at <https://www.sgs.com/en/Terms-and-Conditions>. Attention is drawn to the limitation of liability, indemnification and jurisdiction issues defined therein. Any holder of this document is advised that information contained herein reflects the Company's findings at the time of its intervention only and within the limits of Client's instructions, if any. The Company's sole responsibility is to its Client and this document does not exonerate parties to a transaction from exercising all their rights and obligations under the transaction documents. This document cannot be reproduced except in full, without prior written approval of the Company. Any unauthorized alteration, forgery or falsification of the content or appearance of this document is unlawful and offenders may be prosecuted to the fullest extent of the law. Unless otherwise stated the results shown in this test report refer only to the sample(s) tested and such sample(s) are retained for 30 days only.

Attention: To check the authenticity of testing /inspection report & certificate, please contact us at telephone: (86-755) 8307 1443, or email: CN.Doccheck@sgs.com

No.1 Workshop, M-10, Middle Section, Science & Technology Park, Nanshan District, Shenzhen, Guangdong, China 518057 t (86-755) 26012053 f (86-755) 26710594 www.sgs.com.cn
 中国·广东·深圳市南山区科技园中区M-10栋1号厂房 邮编: 518057 t (86-755) 26012053 f (86-755) 26710594 sgs.china@sgs.com

SGS-CSTC Standards Technical Services Co., Ltd. Shenzhen Branch

SZEMC-TRF-01 Rev. A/0 Aug01,2022

Report No.: SZCR240100025702

Page: 10 of 39

Occupied Bandwidth					
Equipment	Manufacturer	Model No.	Inventory No.	Cal Date	Cal Due Date
DC Power Supply	Chroma	62012P-80-60	SEM011-11	2022-10-20	2023-10-19
MXA Signal Analyzer	KEYSIGHT	N9020A	SEM004-19	2023-03-21	2024-03-20
Signal Generator	KEYSIGHT	N5173B	SEM006-05	2022-09-29	2023-09-28
Measurement Software	TST PASS	TST PASS V2.0	N/A	N/A	N/A
Coaxial Cable	SGS	N/A	SEM031-01	2022-07-08	2023-07-07
Attenuator	Huber+Suhner	6620_SMA-50-1	SEM021-09	2023-03-31	2024-03-30
Programmable Temperature & Humidity Chamber	Votsch Industrietechnik GmbH	VT 4002	SEM002-15	2023-03-21	2024-03-20

Transient power					
Equipment	Manufacturer	Model No.	Inventory No.	Cal Date	Cal Due Date
DC Power Supply	Chroma	62012P-80-60	SEM011-11	2022-10-20	2023-10-19
MXA Signal Analyzer	KEYSIGHT	N9020A	SEM004-19	2023-03-21	2024-03-20
Signal Generator	KEYSIGHT	N5173B	SEM006-05	2022-09-29	2023-09-28
Measurement Software	TST PASS	TST PASS V2.0	N/A	N/A	N/A
Coaxial Cable	SGS	N/A	SEM031-01	2022-07-08	2023-07-07
Attenuator	Huber+Suhner	6620_SMA-50-1	SEM021-09	2023-03-31	2024-03-30
Programmable Temperature & Humidity Chamber	Votsch Industrietechnik GmbH	VT 4002	SEM002-15	2023-03-21	2024-03-20

Adjacent Channel Power					
Equipment	Manufacturer	Model No.	Inventory No.	Cal Date	Cal Due Date
DC Power Supply	Chroma	62012P-80-60	SEM011-11	2022-10-20	2023-10-19
MXA Signal Analyzer	KEYSIGHT	N9020A	SEM004-19	2023-03-21	2024-03-20
Signal Generator	KEYSIGHT	N5173B	SEM006-05	2022-09-29	2023-09-28
Measurement Software	TST PASS	TST PASS V2.0	N/A	N/A	N/A
Coaxial Cable	SGS	N/A	SEM031-01	2022-07-08	2023-07-07
Attenuator	Huber+Suhner	6620_SMA-50-1	SEM021-09	2023-03-31	2024-03-30
Programmable Temperature & Humidity Chamber	Votsch Industrietechnik GmbH	VT 4002	SEM002-15	2023-03-21	2024-03-20



Unless otherwise agreed in writing, this document is issued by the Company subject to its General Conditions of Service printed overleaf, available on request or accessible at <https://www.sgs.com/en/Terms-and-Conditions>. Attention is drawn to the limitation of liability, indemnification and jurisdiction issues defined therein. Any holder of this document is advised that information contained hereon reflects the Company's findings at the time of its intervention only and within the limits of Client's instructions, if any. The Company's sole responsibility is to its Client and this document does not exonerate parties to a transaction from exercising all their rights and obligations under the transaction documents. This document cannot be reproduced except in full, without prior written approval of the Company. Any unauthorized alteration, forgery or falsification of the content or appearance of this document is unlawful and offenders may be prosecuted to the fullest extent of the law. Unless otherwise stated the results shown in this test report refer only to the sample(s) tested and such sample(s) are retained for 30 days only.

Attention: To check the authenticity of testing /inspection report & certificate, please contact us at telephone: (86-755) 8307 1443, or email: CN.Doccheck@sgs.com

No.1 Workshop, M-10, Middle Section, Science & Technology Park, Nanshan District, Shenzhen, Guangdong, China 518057 t (86-755) 26012053 f (86-755) 26710594 www.sgs.com.cn
 中国·广东·深圳市南山区科技园中区M-10栋1号厂房 邮编: 518057 t (86-755) 26012053 f (86-755) 26710594 sgs.china@sgs.com

TX behaviour under Low Voltage Conditions					
Equipment	Manufacturer	Model No.	Inventory No.	Cal Date	Cal Due Date
DC Power Supply	Chroma	62012P-80-60	SEM011-11	2022-10-20	2023-10-19
MXA Signal Analyzer	KEYSIGHT	N9020A	SEM004-19	2023-03-21	2024-03-20
Signal Generator	KEYSIGHT	N5173B	SEM006-05	2022-09-29	2023-09-28
Measurement Software	TST PASS	TST PASS V2.0	N/A	N/A	N/A
Coaxial Cable	SGS	N/A	SEM031-01	2022-07-08	2023-07-07
Attenuator	Huber+Suhner	6620_SMA-50-1	SEM021-09	2023-03-31	2024-03-30
Programmable Temperature & Humidity Chamber	Votsch Industrietechnik GmbH	VT 4002	SEM002-15	2023-03-21	2024-03-20

Blocking					
Equipment	Manufacturer	Model No.	Inventory No.	Cal Date	Cal Due Date
DC Power Supply	Chroma	62012P-80-60	SEM011-11	2022-10-20	2023-10-19
MXA Signal Analyzer	KEYSIGHT	N9020A	SEM004-19	2023-03-21	2024-03-20
Signal Generator	KEYSIGHT	N5173B	SEM006-05	2022-09-29	2023-09-28
Measurement Software	TST PASS	TST PASS V2.0	N/A	N/A	N/A
Coaxial Cable	SGS	N/A	SEM031-01	2022-07-08	2023-07-07
Attenuator	Huber+Suhner	6620_SMA-50-1	SEM021-09	2023-03-31	2024-03-30
Programmable Temperature & Humidity Chamber	Votsch Industrietechnik GmbH	VT 4002	SEM002-15	2023-03-21	2024-03-20

General used equipment					
Equipment	Manufacturer	Model No.	Inventory No.	Cal Date	Cal Due Date
Humidity/ Temperature Indicator	Mingle	N/A	SEM002-08	2022-09-04	2023-09-03
Humidity/ Temperature Indicator	Anymetre	TH101B	SEM002-09	2022-09-04	2023-09-03
Barometer	Changchun Meteorological Industry Factory	DYM3	SEM002-01	2023-03-23	2024-03-22



Unless otherwise agreed in writing, this document is issued by the Company subject to its General Conditions of Service printed overleaf, available on request or accessible at <https://www.sgs.com/en/Terms-and-Conditions>. Attention is drawn to the limitation of liability, indemnification and jurisdiction issues defined therein. Any holder of this document is advised that information contained hereon reflects the Company's findings at the time of its intervention only and within the limits of Client's instructions, if any. The Company's sole responsibility is to its Client and this document does not exonerate parties to a transaction from exercising all their rights and obligations under the transaction documents. This document cannot be reproduced except in full, without prior written approval of the Company. Any unauthorized alteration, forgery or falsification of the content or appearance of this document is unlawful and offenders may be prosecuted to the fullest extent of the law. Unless otherwise stated the results shown in this test report refer only to the sample(s) tested and such sample(s) are retained for 30 days only.

Attention: To check the authenticity of testing /inspection report & certificate, please contact us at telephone: (86-755) 8307 1443, or email: CN.Doccheck@sgs.com

No.1 Workshop, M-10, Middle Section, Science & Technology Park, Nanshan District, Shenzhen, Guangdong, China 518057 t (86-755) 26012053 f (86-755) 26710594 www.sgs.com.cn
 中国·广东·深圳市南山区科技园中区M-10栋1号厂房 邮编: 518057 t (86-755) 26012053 f (86-755) 26710594 sgs.china@sgs.com

6 Radio Spectrum Matter Test Results

6.1 Operating frequency

Test Requirement EN 300 220-2 V3.2.1 clause 4.2.1

Test Method: EN 300 220-1 V3.1.1 clause 5.1.2

Limit:

Operating channel(s) shall be entirely within operational frequency bands allowed by annex B or any NRI.

6.1.1 E.U.T. Operation

Operating Environment:

Temperature: 28.2 °C Humidity: 48.0 % RH Atmospheric Pressure: 1015 mbar

6.1.2 Test Mode Description

Pre-scan / Final test	Mode Code	Description
Final test	02	TX mode_Keep the EUT in transmitting mode

6.1.3 Test Setup Diagram

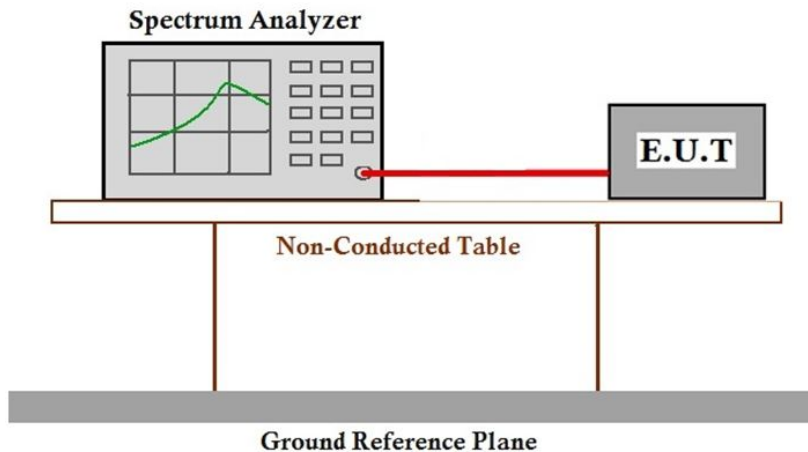

6.1.4 Measurement Procedure and Data

Declared by the manufacturer

Please Refer to Appendix for Details



Unless otherwise agreed in writing, this document is issued by the Company subject to its General Conditions of Service printed overleaf, available on request or accessible at <https://www.sgs.com/en/Terms-and-Conditions>. Attention is drawn to the limitation of liability, indemnification and jurisdiction issues defined therein. Any holder of this document is advised that information contained hereon reflects the Company's findings at the time of its intervention only and within the limits of Client's instructions, if any. The Company's sole responsibility is to its Client and this document does not exonerate parties to a transaction from exercising all their rights and obligations under the transaction documents. This document cannot be reproduced except in full, without prior written approval of the Company. Any unauthorized alteration, forgery or falsification of the content or appearance of this document is unlawful and offenders may be prosecuted to the fullest extent of the law. Unless otherwise stated the results shown in this test report refer only to the sample(s) tested and such sample(s) are retained for 30 days only.

Attention: To check the authenticity of testing /inspection report & certificate, please contact us at telephone: (86-755) 8307 1443, or email: CN.Doccheck@sgs.com

No.1 Workshop, M-10, Middle Section, Science & Technology Park, Nanshan District, Shenzhen, Guangdong, China 518057 t (86-755) 26012053 f (86-755) 26710594 www.sgsgroup.com.cn
 中国·广东·深圳市南山区科技园中区M-10栋1号厂房 邮编: 518057 t (86-755) 26012053 f (86-755) 26710594 sgs.china@sgs.com

6.2 Unwanted emissions in the spurious domain

Test Requirement EN 300 220-2 V3.2.1 clause 4.2.2

Test Method: EN 300 220-1 V3.1.1 clause 5.9.3

Measurement Distance: 3m

Limit:

Table 19: Spurious domain emission limits

Frequency \ State	47 MHz to 74 MHz; 87,5 MHz to 118 MHz; 174 MHz to 230 MHz; 470 MHz to 790 MHz	Other frequencies below 1 000 MHz	Frequencies above 1 000 MHz
TX mode	-54 dBm	-36 dBm	-30 dBm
RX and all other modes	-57 dBm	-57 dBm	-47 dBm

6.2.1 E.U.T. Operation

Operating Environment:

Temperature: 23.6 °C Humidity: 52.5 % RH Atmospheric Pressure: 1015 mbar

6.2.2 Test Mode Description

Pre-scan / Final test	Mode Code	Description
Final test	02	TX mode_Keep the EUT in transmitting mode
Final test	03	RX mode_Keep the EUT in receiving mode



Unless otherwise agreed in writing, this document is issued by the Company subject to its General Conditions of Service printed overleaf, available on request or accessible at <https://www.sgs.com/en/Terms-and-Conditions>. Attention is drawn to the limitation of liability, indemnification and jurisdiction issues defined therein. Any holder of this document is advised that information contained hereon reflects the Company's findings at the time of its intervention only and within the limits of Client's instructions, if any. The Company's sole responsibility is to its Client and this document does not exonerate parties to a transaction from exercising all their rights and obligations under the transaction documents. This document cannot be reproduced except in full, without prior written approval of the Company. Any unauthorized alteration, forgery or falsification of the content or appearance of this document is unlawful and offenders may be prosecuted to the fullest extent of the law. Unless otherwise stated the results shown in this test report refer only to the sample(s) tested and such sample(s) are retained for 30 days only.

Attention: To check the authenticity of testing /inspection report & certificate, please contact us at telephone: (86-755) 8307 1443, or email: CN.Doccheck@sgs.com

No.1 Workshop, M-10, Middle Section, Science & Technology Park, Nanshan District, Shenzhen, Guangdong, China 518057 t (86-755) 26012053 f (86-755) 26710594 www.sgs.com.cn
 中国·广东·深圳市南山区科技园中区M-10栋1号厂房 邮编: 518057 t (86-755) 26012053 f (86-755) 26710594 sgs.china@sgs.com

6.2.3 Test Setup Diagram

30MHz to 1GHz

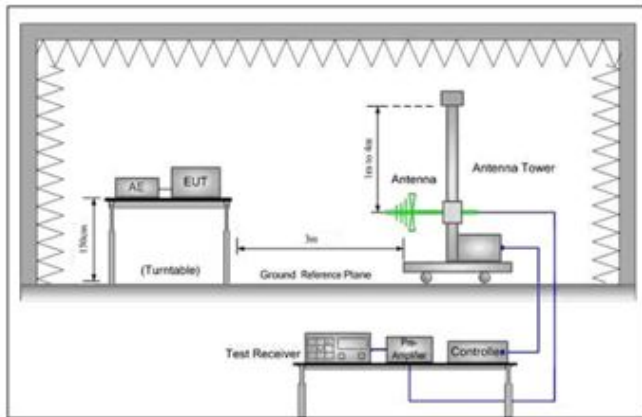

Above 1GHz

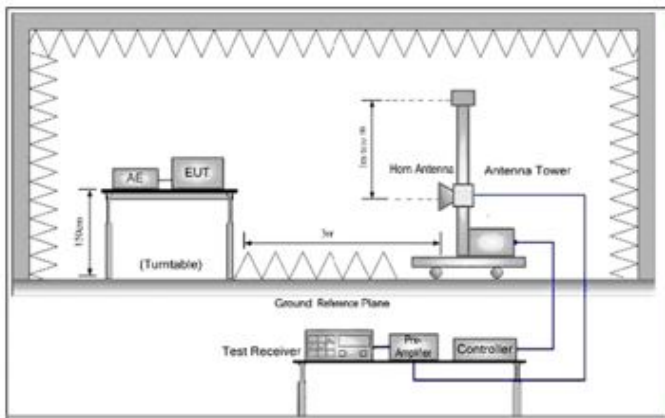

6.2.4 Measurement Procedure and Data

Below 1GHz test procedure as below:

- 1) The EUT was powered ON and placed on a 1.5m high table in the chamber. The antenna of the transmitter was extended to its maximum length. Modulation mode and the measuring receiver shall be tuned to the frequency of the transmitter under test.
- 2) The disturbance of the transmitter was maximized on the test receiver display by raising and lowering from 1m to 4m the receive antenna and by rotating through 360° the turntable. After the fundamental emission was maximized, a field strength measurement was made.
- 3) Steps 1) and 2) were performed with the EUT and the receive antenna in both vertical and horizontal polarization.
- 4) The transmitter was then removed and replaced with another antenna. The center of the antenna was approximately at the same location as the center of the transmitter.
- 5) A signal at the disturbance was fed to the substitution antenna by means of a non-radiating cable. With both the substitution and the receive antennas horizontally polarized, the receive antenna was raised and lowered to obtain a maximum reading at the test receiver. The level of the signal generator was adjusted until the measured field strength level in step 2) is obtained for this set of conditions.
- 6) The output power into the substitution antenna was then measured.
- 7) Steps 5) and 6) were repeated with both antennas polarized.
- 8) Calculate power in dBm by the following formula:

$$ERP(dBm) = Pg(dBm) - \text{cable loss (Db)} + \text{antenna gain (dBd)}$$

where: Pg is the generator output power into the substitution antenna.

Above 1GHz test procedure as below:

- 1) Different between above is the test site, change from Semi- Anechoic Chamber to fully Anechoic Chamber and receiving antenna is moved from 1m to 2m.
- 2) Calculate power in dBm by the following formula:

$$EIRP(dBm) = Pg(dBm) - \text{cable loss (Db)} + \text{antenna gain (dBi)} \quad EIRP=ERP+2.15dB$$

where:

Pg is the generator output power into the substitution antenna. Standby mode test procedure as below:

- 1) Below 1GHz test procedure Steps 1) to 8) and Above 1GHz test procedure 1) to 2) shall be repeated with the transmitter in the standby condition if this option is available.
- 2) Tests were conducted in all four frequency bands and the worst case is reported only.
- 3) The Radiated Emissions measurement results above 1GHz-range have a margin of at least 10dB

Remark:

- 1) For measurements above 1 000 MHz ,the peak detector has been used.
- 2) For measurements 30MHz to 1 000 MHz ,the quasi-peak detector has been used.



Mode 02:

Tx mode				
Maximum Frequency	Spurious Emission position and Level		Limit	Over Limit
	MHz	Polarity		
54.146	V	-69.2	-54	-15.2
99.965	V	-78.16	-54	-24.16
202.189	V	-80.49	-54	-26.49
496.221	V	-74.61	-54	-20.61
635.999	V	-71.48	-54	-17.48
744.068	V	-71.35	-54	-17.35
54.146	H	-71.92	-54	-17.92
100.331	H	-77.78	-54	-23.78
176.65	H	-79.14	-54	-25.14
529.914	H	-73.81	-54	-19.81
650.08	H	-74.45	-54	-20.45
763.322	H	-70.88	-54	-16.88

Mode 03:

Rx mode				
Maximum Frequency	Spurious Emission Level		Limit	Over Limit
	MHz	Polaxis		
49.533	V	-75.3	-57	-18.3
95.093	V	-80.27	-57	-23.27
176.888	V	-78.88	-57	-21.88
425.028	V	-76.22	-57	-19.22
638.369	V	-72.08	-57	-15.08
866.088	V	-69.01	-57	-12.01
58.613	H	-77.88	-57	-20.88
100.581	H	-79.62	-57	-22.62
175.037	H	-77.68	-57	-20.68
428.019	H	-76.78	-57	-19.78
638.369	H	-73.33	-57	-16.33
912.862	H	-70.64	-57	-13.64

Remark:

The disturbance above 1GHz was very low, and the above harmonics were the highest point could be found when testing, so only the above harmonics had been displayed



Unless otherwise agreed in writing, this document is issued by the Company subject to its General Conditions of Service printed overleaf, available on request or accessible at <https://www.sgs.com/en/Terms-and-Conditions>. Attention is drawn to the limitation of liability, indemnification and jurisdiction issues defined therein. Any holder of this document is advised that information contained hereon reflects the Company's findings at the time of its intervention only and within the limits of Client's instructions, if any. The Company's sole responsibility is to its Client and this document does not exonerate parties to a transaction from exercising all their rights and obligations under the transaction documents. This document cannot be reproduced except in full, without prior written approval of the Company. Any unauthorized alteration, forgery or falsification of the content or appearance of this document is unlawful and offenders may be prosecuted to the fullest extent of the law. Unless otherwise stated the results shown in this test report refer only to the sample(s) tested and such sample(s) are retained for 30 days only.
Attention: To check the authenticity of testing /inspection report & certificate, please contact us at telephone: (86-755) 8307 1443, or email: CN.Doccheck@sgs.com
 No.1 Workshop, M-10, Middle Section, Science & Technology Park, Nanshan District, Shenzhen, Guangdong, China 518057 t (86-755) 26012053 f (86-755) 26710594 www.sgs.com.cn
 中国·广东·深圳市南山区科技园中区M-10栋1号厂房 邮编: 518057 t (86-755) 26012053 f (86-755) 26710594 sgs.china@sgs.com

6.3 Effective Radiated Power

Test Requirement EN 300 220-2 V3.2.1 clause 4.3.1
 Test Method: EN 300 220-1 V3.1.1 clause 5.2.2
 Measurement Distance: 3m

Limit:

Operational Frequency Band		Maximum effective radiated power, e.r.p.	Channel access and occupation rules (e.g. Duty cycle or LBT + AFA)	Maximum occupied bandwidth	Other usage restrictions
A	26,957 MHz to 27,283 MHz	10 mW e.r.p.	No requirement	The whole band	
C	40,660 MHz to 40,700 MHz	10 mW e.r.p.	No requirement	The whole band	Video applications excluded.
H	433,050 MHz to 434,790 MHz	10 mW	10 %	The whole band	
I	433,050 MHz to 434,790 MHz	1 mW e.r.p. -13 dBm/10 kHz power spectral density for bandwidth modulation larger than 250 kHz	No requirement	The whole band	Audio and video applications are excluded.
J	434,040 MHz to 434,790 MHz	10 mW	No requirement	25 kHz	Audio and video applications are excluded.
K	863 MHz to 865 MHz	25 mW e.r.p.	≤ 0,1 % duty cycle or polite spectrum access	The whole band except for audio & video applications limited to 300 kHz	
L	865 MHz to 868 MHz	25 mW e.r.p.	≤ 1 % duty cycle or polite spectrum access	The whole band	
M	868,000 MHz to 868,600 MHz	25 mW e.r.p.	≤ 1 % duty cycle or polite spectrum access	The whole band	
N	868,700 MHz to 869,200 MHz	25 mW e.r.p.	≤ 0,1 % duty cycle or polite spectrum access	The whole sub-band	
P	869,400 MHz to 869,650 MHz	500 mW e.r.p.	≤ 10 % duty cycle or polite spectrum access	The whole band	
P	869,700 MHz to 870,000 MHz	5 mW e.r.p.	No requirement	The whole band	Audio and video applications are excluded.
Q	869,700 MHz to 870,000 MHz	25 mW e.r.p.	≤ 1 % duty cycle or polite spectrum access	The whole band	Analogue audio applications are excluded. Analogue video applications are excluded.



Unless otherwise agreed in writing, this document is issued by the Company subject to its General Conditions of Service printed overleaf, available on request or accessible at <https://www.sgs.com/en/Terms-and-Conditions>. Attention is drawn to the limitation of liability, indemnification and jurisdiction issues defined therein. Any holder of this document is advised that information contained hereon reflects the Company's findings at the time of its intervention only and within the limits of Client's instructions, if any. The Company's sole responsibility is to its Client and this document does not exonerate parties to a transaction from exercising all their rights and obligations under the transaction documents. This document cannot be reproduced except in full, without prior written approval of the Company. Any unauthorized alteration, forgery or falsification of the content or appearance of this document is unlawful and offenders may be prosecuted to the fullest extent of the law. Unless otherwise stated the results shown in this test report refer only to the sample(s) tested and such sample(s) are retained for 30 days only.

Attention: To check the authenticity of testing /inspection report & certificate, please contact us at telephone: (86-755) 8307 1443, or email: CN.Doccheck@sgs.com

No.1 Workshop, M-10, Middle Section, Science & Technology Park, Nanshan District, Shenzhen, Guangdong, China 518057 t (86-755) 26012053 f (86-755) 26710594 www.sgsgroup.com.cn
 中国·广东·深圳市南山区科技园中区M-10栋1号厂房 邮编: 518057 t (86-755) 26012053 f (86-755) 26710594 sgs.china@sgs.com

6.3.1 E.U.T. Operation

Operating Environment:

Temperature: 23.6 °C Humidity: 52.5 % RH Atmospheric Pressure: 1015 mbar

6.3.2 Test Mode Description

Pre-scan / Final test	Mode Code	Description
Final test	02	TX mode_Keep the EUT in transmitting mode

6.3.3 Test Setup Diagram

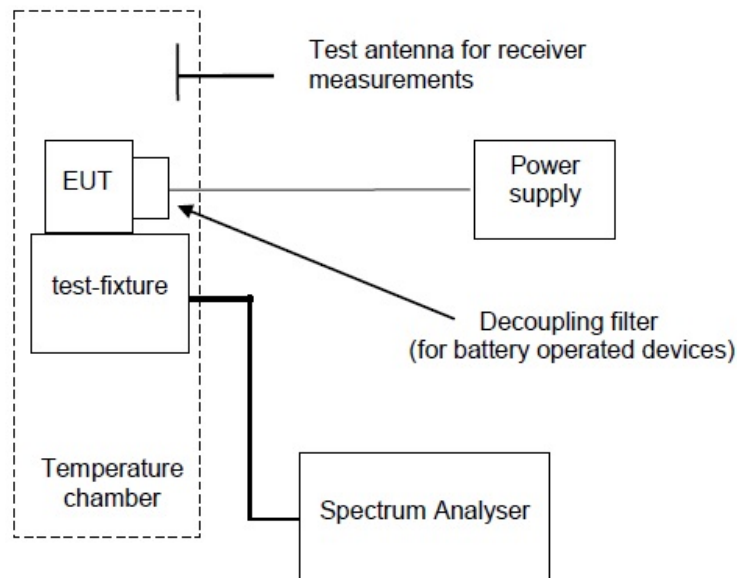
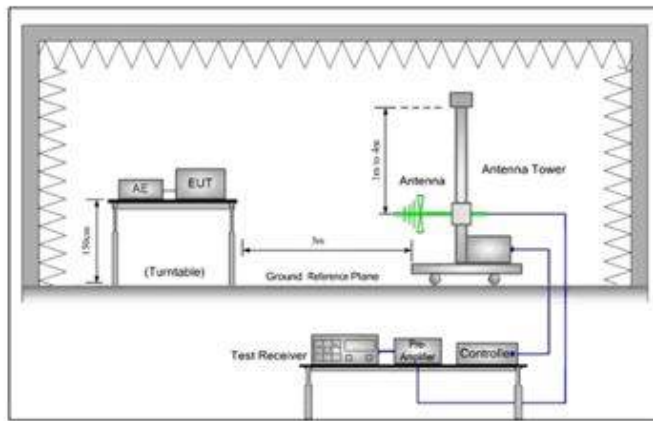

6.3.4 Measurement Procedure and Data

- 1) The EUT was powered ON and placed on a 1.5m high table in the chamber. The antenna of the transmitter was extended to its maximum length. Receiver mode and the measuring receiver shall be tuned to the frequency of the transmitter under test.
- 2) The disturbance of the transmitter was maximized on the test receiver display by raising and lowering from 1m to 4m the receive antenna and by rotating through 360° the turntable. After the fundamental emission was maximized, a field strength measurement was made.
- 3) Steps 1) and 2) were performed with the EUT and the receive antenna in both vertical and horizontal polarization.
- 4) The transmitter was then removed and replaced with another antenna. The center of the antenna was approximately at the same location as the center of the transmitter.
- 5) A signal at the disturbance was fed to the substitution antenna by means of a non-radiating cable. With both the substitution and the receive antennas horizontally polarized, the receive antenna was raised and lowered to obtain a maximum reading at the test receiver. The level of the signal generator was adjusted until the measured field strength level in step 2) is obtained for this set of conditions.
- 6) The output power into the substitution antenna was then measured.
- 7) Steps 5) and 6) were repeated with both antennas polarized.
- 8) Calculate power in dBm by the following formula: $ERP(dBm) = Pg(dBm) - \text{cable loss (dB)} + \text{antenna gain (dBd)}$ where: Pg is the generator output power into the substitution antenna.

Please Refer to Appendix for Details.



6.4 Duty Cycle

Test Requirement EN 300 220-2 V3.2.1 clause 4.3.3

Test Method: EN 300 220-1 V3.1.1 clause 5.4.2

According to the EN 300 220-2 Clause 4.3.3.0 table B.1, no duty cycle restriction in 26.957MHz to 27.283 MHz.



6.5 Occupied Bandwidth

Test Requirement EN 300 220-2 V3.2.1 clause 4.3.4

Test Method: EN 300 220-1 V3.1.1 clause 5.6.3

Limit:

Operational Frequency Band		Maximum effective radiated power, e.r.p.	Channel access and occupation rules (e.g. Duty cycle or LBT + AFA)	Maximum occupied bandwidth	Other usage restrictions
A	26,957 MHz to 27,283 MHz	10 mW e.r.p.	No requirement	The whole band	
C	40,660 MHz to 40,700 MHz	10 mW e.r.p.	No requirement	The whole band	Video applications excluded.
H	433,050 MHz to 434,790 MHz	10 mW	10 %	The whole band	
I	433,050 MHz to 434,790 MHz	1 mW e.r.p. -13 dBm/10 kHz power spectral density for bandwidth modulation larger than 250 kHz	No requirement	The whole band	Audio and video applications are excluded.
J	434,040 MHz to 434,790 MHz	10 mW	No requirement	25 kHz	Audio and video applications are excluded.
K	863 MHz to 865 MHz	25 mW e.r.p.	≤ 0,1 % duty cycle or polite spectrum access	The whole band except for audio & video applications limited to 300 kHz	
L	865 MHz to 868 MHz	25 mW e.r.p.	≤ 1 % duty cycle or polite spectrum access	The whole band	
M	868,000 MHz to 868,600 MHz	25 mW e.r.p.	≤ 1 % duty cycle or polite spectrum access	The whole band	
N	868,700 MHz to 869,200 MHz	25 mW e.r.p.	≤ 0,1 % duty cycle or polite spectrum access	The whole sub-band	
P	869,400 MHz to 869,650 MHz	500 mW e.r.p.	≤ 10 % duty cycle or polite spectrum access	The whole band	
P	869,700 MHz to 870,000 MHz	5 mW e.r.p.	No requirement	The whole band	Audio and video applications are excluded.
Q	869,700 MHz to 870,000 MHz	25 mW e.r.p.	≤ 1 % duty cycle or polite spectrum access	The whole band	Analogue audio applications are excluded. Analogue video applications are excluded.



6.5.1 E.U.T. Operation

Operating Environment:

Temperature: 28.2 °C Humidity: 48.0 % RH Atmospheric Pressure: 1015 mbar

6.5.2 Test Mode Description

Pre-scan / Final test	Mode Code	Description
Final test	02	TX mode_Keep the EUT in transmitting mode

6.5.3 Test Setup Diagram

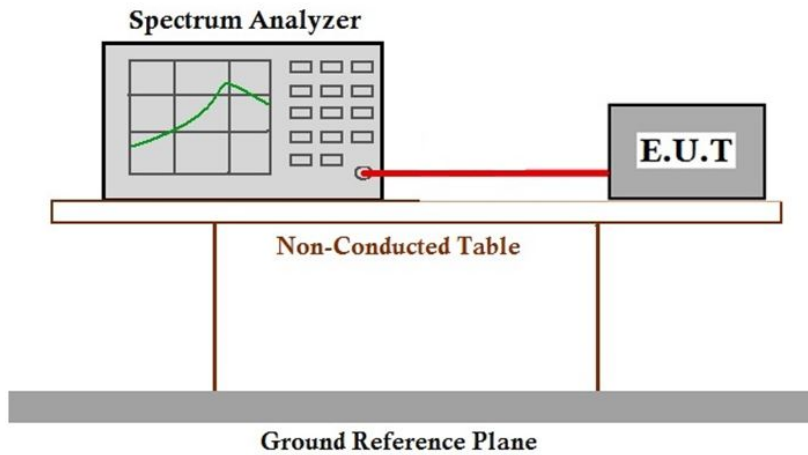

Unless otherwise agreed in writing, this document is issued by the Company subject to its General Conditions of Service printed overleaf, available on request or accessible at <https://www.sgs.com/en/Terms-and-Conditions>. Attention is drawn to the limitation of liability, indemnification and jurisdiction issues defined therein. Any holder of this document is advised that information contained hereon reflects the Company's findings at the time of its intervention only and within the limits of Client's instructions, if any. The Company's sole responsibility is to its Client and this document does not exonerate parties to a transaction from exercising all their rights and obligations under the transaction documents. This document cannot be reproduced except in full, without prior written approval of the Company. Any unauthorized alteration, forgery or falsification of the content or appearance of this document is unlawful and offenders may be prosecuted to the fullest extent of the law. Unless otherwise stated the results shown in this test report refer only to the sample(s) tested and such sample(s) are retained for 30 days only.

Attention: To check the authenticity of testing /inspection report & certificate, please contact us at telephone: (86-755) 8307 1443, or email: CN.Doccheck@sgs.com

No.1 Workshop, M-10, Middle Section, Science & Technology Park, Nanshan District, Shenzhen, Guangdong, China 518057 t (86-755) 26012053 f (86-755) 26710594 www.sgs.com.cn
中国·广东·深圳市南山区科技园中区M-10栋1号厂房 邮编: 518057 t (86-755) 26012053 f (86-755) 26710594 sgs.china@sgs.com

6.5.4 Measurement Procedure and Data

The spectrum analyser shall be configured as appropriate for the parameters shown in Table 12.

Step 1:

Operation of the EUT shall be started, on the highest operating frequency as declared by the manufacturer, with the appropriate test signal.

The signal attenuation shall be adjusted to ensure that the signal power envelope is sufficiently above the noise floor of

the analyser to avoid the noise signals on either side of the power envelope being included in the measurement.

Step 2:

When the trace is completed the peak value of the trace shall be located and the analyser marker placed on this peak.

Step 3:

The 99 % occupied bandwidth function of the spectrum analyser shall be used to measure the occupied bandwidth of

the signal.

Please Refer to Appendix for Details.



Unless otherwise agreed in writing, this document is issued by the Company subject to its General Conditions of Service printed overleaf, available on request or accessible at <https://www.sgs.com/en/Terms-and-Conditions>. Attention is drawn to the limitation of liability, indemnification and jurisdiction issues defined therein. Any holder of this document is advised that information contained hereon reflects the Company's findings at the time of its intervention only and within the limits of Client's instructions, if any. The Company's sole responsibility is to its Client and this document does not exonerate parties to a transaction from exercising all their rights and obligations under the transaction documents. This document cannot be reproduced except in full, without prior written approval of the Company. Any unauthorized alteration, forgery or falsification of the content or appearance of this document is unlawful and offenders may be prosecuted to the fullest extent of the law. Unless otherwise stated the results shown in this test report refer only to the sample(s) tested and such sample(s) are retained for 30 days only.

Attention: To check the authenticity of testing /inspection report & certificate, please contact us at telephone: (86-755) 8307 1443, or email: CN.Doccheck@sgs.com

6.6 Transient power

Test Requirement EN 300 220-2 V3.2.1 clause 4.3.6
 Test Method: EN 300 220-1 V3.1.1 clause 5.10.3

Limit:

Table 23: Transmitter Transient Power limits

Absolute offset from centre frequency	RBW _{REF}	Peak power limit applicable at measurement points
≤ 400 kHz	1 kHz	0 dBm
> 400 kHz	1 kHz	-27 dBm

6.6.1 E.U.T. Operation

Operating Environment:
 Temperature: 28.2 °C Humidity: 48.0 % RH Atmospheric Pressure: 1015 mbar

6.6.2 Test Mode Description

Pre-scan / Final test	Mode Code	Description
Final test	02	TX mode_Keep the EUT in transmitting mode



Unless otherwise agreed in writing, this document is issued by the Company subject to its General Conditions of Service printed overleaf, available on request or accessible at <https://www.sgs.com/en/Terms-and-Conditions>. Attention is drawn to the limitation of liability, indemnification and jurisdiction issues defined therein. Any holder of this document is advised that information contained hereon reflects the Company's findings at the time of its intervention only and within the limits of Client's instructions, if any. The Company's sole responsibility is to its Client and this document does not exonerate parties to a transaction from exercising all their rights and obligations under the transaction documents. This document cannot be reproduced except in full, without prior written approval of the Company. Any unauthorized alteration, forgery or falsification of the content or appearance of this document is unlawful and offenders may be prosecuted to the fullest extent of the law. Unless otherwise stated the results shown in this test report refer only to the sample(s) tested and such sample(s) are retained for 30 days only.
Attention: To check the authenticity of testing /inspection report & certificate, please contact us at telephone: (86-755) 8307 1443, or email: CN.Doccheck@sgs.com
 No.1 Workshop, M-10, Middle Section, Science & Technology Park, Nanshan District, Shenzhen, Guangdong, China 518057 t (86-755) 26012053 f (86-755) 26710594 www.sgs.com.cn
 中国·广东·深圳市南山区科技园中区M-10栋1号厂房 邮编: 518057 t (86-755) 26012053 f (86-755) 26710594 sgs.china@sgs.com

6.6.3 Test Setup Diagram

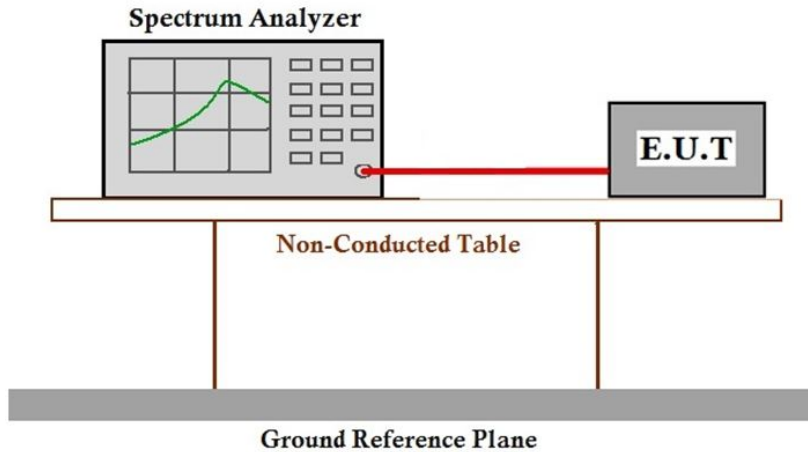

6.6.4 Measurement Procedure and Data

The output of the EUT shall be connected to a spectrum analyser or equivalent measuring equipment.

The measurement shall be undertaken in zero span mode. The analyser's centre frequency shall be set to an offset from

the operating centre frequency. These offset values and their corresponding RBW configurations are listed in Table 24.

The used modulation shall be D-M3. The analyser shall be set to the settings of Table 25 and a measurement shall be

started for each offset frequency. The EUT shall transmit at least five D-M3 test signal. The peak value shall be

recorded and the measurement shall be repeated at each offset frequency mentioned in Table 24.

Please Refer to Appendix for Details.



6.7 Adjacent Channel Power

Test Requirement EN 300 220-2 V3.2.1 clause 4.3.7
 Test Method: EN 300 220-1 V3.1.1 clause 5.11.3

Limit:

Table 26: Adjacent channel power limits for transmitters with OCW ≤ 25 kHz

		Adjacent Channel power integrated over 0,7 x OCW	Alternate Adjacent Channel power integrated over 0,7 x OCW
OCW < 20 kHz	Normal test conditions	-20 dBm	-20 dBm
	Extreme test conditions	-15 dBm	-20 dBm
OCW ≥20 kHz	Normal test conditions	-37 dBm	-40 dBm
	Extreme test conditions	-32 dBm	-37 dBm

6.7.1 E.U.T. Operation

Operating Environment:

Temperature: 28.2 °C Humidity: 48.0 % RH Atmospheric Pressure: 1015 mbar

6.7.2 Test Mode Description

Pre-scan / Final test	Mode Code	Description
Final test	02	TX mode_ Keep the EUT in transmitting mode



Unless otherwise agreed in writing, this document is issued by the Company subject to its General Conditions of Service printed overleaf, available on request or accessible at <https://www.sgs.com/en/Terms-and-Conditions>. Attention is drawn to the limitation of liability, indemnification and jurisdiction issues defined therein. Any holder of this document is advised that information contained hereon reflects the Company's findings at the time of its intervention only and within the limits of Client's instructions, if any. The Company's sole responsibility is to its Client and this document does not exonerate parties to a transaction from exercising all their rights and obligations under the transaction documents. This document cannot be reproduced except in full, without prior written approval of the Company. Any unauthorized alteration, forgery or falsification of the content or appearance of this document is unlawful and offenders may be prosecuted to the fullest extent of the law. Unless otherwise stated the results shown in this test report refer only to the sample(s) tested and such sample(s) are retained for 30 days only.
Attention: To check the authenticity of testing /inspection report & certificate, please contact us at telephone: (86-755) 8307 1443, or email: CN.Doccheck@sgs.com
 No.1 Workshop, M-10, Middle Section, Science & Technology Park, Nanshan District, Shenzhen, Guangdong, China 518057 t (86-755) 26012053 f (86-755) 26710594 www.sgs.com.cn
 中国·广东·深圳市南山区科技园中区M-10栋1号厂房 邮编: 518057 t (86-755) 26012053 f (86-755) 26710594 sgs.china@sgs.com

6.7.3 Test Setup Diagram

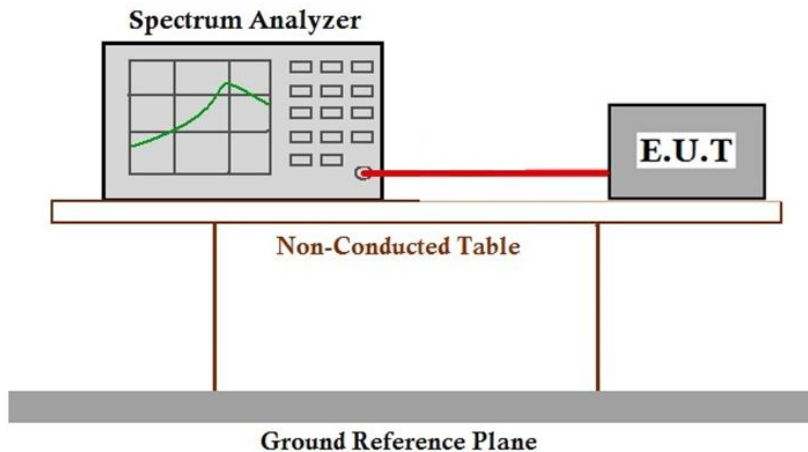

6.7.4 Measurement Procedure and Data

The spectrum analyser shall be configured as appropriate for the parameters shown in Table 27.

Step 1:

Operation of the EUT shall be started, on the Operating Frequency as declared by the manufacturer. The modulation used shall be set according to Table 2.

The signal attenuation shall be adjusted to ensure that the signal power is not saturating the Spectrum analyser input port.

Step 2:

When the trace is completed, read the integrated power over a bandwidth of RBWREF centered to an offset from centre frequency as specified in Table 28. The spectrum analyser's ACP personality or an integrating marker may be used. If the spectrum analyser's ACP personality is used any additional filtering over the integrating bandwidth shall be disabled.

For extreme test conditions, if the measurement is performed under normal conditions only, for EUT generating D-M1 test signal measurement can be performed with the following frequency offsets from centre frequency:

+OCW - |Negative Frequency Error| / -OCW + |Positive Frequency Error| apply for the adjacent channel
 +2xOCW - |Negative Frequency Error| / -2xOCW + |Positive Frequency Error| apply for the alternate adjacent channel.

Take the higher power value from the positive and negative offsets at both the adjacent channel and alternate channel results.

Please Refer to Appendix for Details.



6.8 TX behaviour under Low Voltage Conditions

Test Requirement EN 300 220-2 V3.2.1 clause 4.3.8
 Test Method: EN 300 220-1 V3.1.1 clause 5.12.3

Limit:

The equipment shall either:

- a) remain in the Operating Channel OC without exceeding any applicable limits (e.g. Duty Cycle); or
 - b) reduce its effective radiated power below the Spurious Emission limits without exceeding any applicable limits(e.g. Duty Cycle); or
 - c) shut down, (ceasing function);
- as the voltage falls below the manufacturers declared operating voltage.

6.8.1 E.U.T. Operation

Operating Environment:

Temperature: 28.2 °C Humidity: 48.0 % RH Atmospheric Pressure: 1015 mbar

6.8.2 Test Mode Description

Pre-scan / Final test	Mode Code	Description
Final test	02	TX mode_Keep the EUT in transmitting mode



Unless otherwise agreed in writing, this document is issued by the Company subject to its General Conditions of Service printed overleaf, available on request or accessible at <https://www.sgs.com/en/Terms-and-Conditions>. Attention is drawn to the limitation of liability, indemnification and jurisdiction issues defined therein. Any holder of this document is advised that information contained hereon reflects the Company's findings at the time of its intervention only and within the limits of Client's instructions, if any. The Company's sole responsibility is to its Client and this document does not exonerate parties to a transaction from exercising all their rights and obligations under the transaction documents. This document cannot be reproduced except in full, without prior written approval of the Company. Any unauthorized alteration, forgery or falsification of the content or appearance of this document is unlawful and offenders may be prosecuted to the fullest extent of the law. Unless otherwise stated the results shown in this test report refer only to the sample(s) tested and such sample(s) are retained for 30 days only.

Attention: To check the authenticity of testing /inspection report & certificate, please contact us at telephone: (86-755) 8307 1443, or email: CN.Doccheck@sgs.com

SGS-CSTC Standards Technical Services Co., Ltd. Shenzhen Branch
 No.1 Workshop, M-10, Middle Section, Science & Technology Park, Nanshan District, Shenzhen, Guangdong, China 518057 t (86-755) 26012053 f (86-755) 26710594 www.sgsgroup.com.cn
 中国·广东·深圳市南山区科技园中区M-10栋1号厂房 邮编: 518057 t (86-755) 26012053 f (86-755) 26710594 sgs.china@sgs.com

6.8.3 Test Setup Diagram

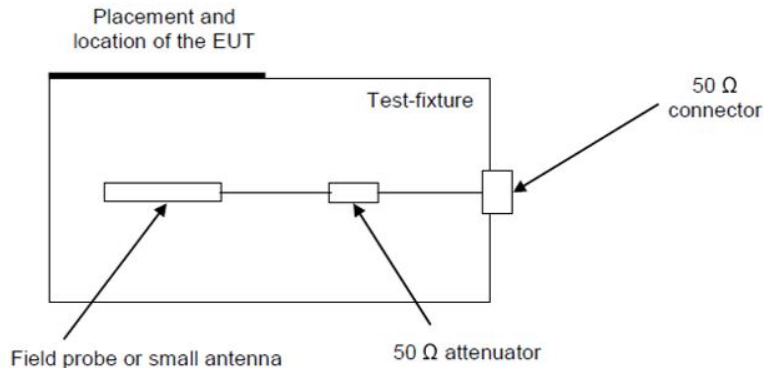

6.8.4 Measurement Procedure and Data

Step 1:

Operation of the EUT shall be started, on Operating Frequency as declared by the manufacturer, with the appropriate test signal and with the EUT operating at nominal operating voltage. The centre frequency of the transmitted signal shall be measured and noted.

Step 2:

The operating voltage shall be reduced by appropriate steps until the voltage reaches zero. The centre frequency of the transmitted signal shall be measured and noted. Any abnormal behaviour shall be noted.

Please Refer to Appendix for Details.



6.9 Blocking

Test Requirement EN 300 220-2 V3.2.1 clause 4.4.2
 Test Method: EN 300 220-1 V3.1.1 clause 5.18.6

Limit:

Table 41: Blocking level parameters for RX category 2

Requirement	Limits
	Receiver category 2
Blocking at ± 2 MHz from OC edge f_{high} and f_{low}	≥ -69 dBm
Blocking at ± 10 MHz from OC edge f_{high} and f_{low}	≥ -44 dBm
Blocking at ± 5 % of Centre Frequency or 15 MHz, whichever is the greater	≥ -44 dBm

Table 42: Blocking level parameters for RX category 1.5

Requirement	Limits
	Receiver category 1.5
Blocking at ± 2 MHz from OC edge f_{high} and f_{low}	≥ -43 dBm
Blocking at ± 10 MHz from OC edge f_{high} and f_{low}	≥ -33 dBm
Blocking at ± 5 % of Centre Frequency or 15 MHz, whichever is the greater	≥ -33 dBm

Table 41: Blocking level parameters for RX category 1

Requirement	Limits
	Receiver category 1
Blocking at ± 2 MHz from OC edge f_{high} and f_{low}	≥ -20 dBm
Blocking at ± 10 MHz from OC edge f_{high} and f_{low}	≥ -20 dBm
Blocking at ± 5 % of Centre Frequency or 15 MHz, whichever is the greater	≥ -20 dBm



Unless otherwise agreed in writing, this document is issued by the Company subject to its General Conditions of Service printed overleaf, available on request or accessible at <https://www.sgs.com/en/Terms-and-Conditions>. Attention is drawn to the limitation of liability, indemnification and jurisdiction issues defined therein. Any holder of this document is advised that information contained hereon reflects the Company's findings at the time of its intervention only and within the limits of Client's instructions, if any. The Company's sole responsibility is to its Client and this document does not exonerate parties to a transaction from exercising all their rights and obligations under the transaction documents. This document cannot be reproduced except in full, without prior written approval of the Company. Any unauthorized alteration, forgery or falsification of the content or appearance of this document is unlawful and offenders may be prosecuted to the fullest extent of the law. Unless otherwise stated the results shown in this test report refer only to the sample(s) tested and such sample(s) are retained for 30 days only.

Attention: To check the authenticity of testing /inspection report & certificate, please contact us at telephone: (86-755) 8307 1443, or email: CN.Doccheck@sgs.com

No.1 Workshop, M-10, Middle Section, Science & Technology Park, Nanshan District, Shenzhen, Guangdong, China 518057 t (86-755) 26012053 f (86-755) 26710594 www.sgs.com.cn
 中国·广东·深圳市南山区科技园中区M-10栋1号厂房 邮编: 518057 t (86-755) 26012053 f (86-755) 26710594 sgs.china@sgs.com

6.9.1 E.U.T. Operation

Operating Environment:

Temperature: 28.2 °C Humidity: 48.0 % RH Atmospheric Pressure: 1015 mbar

6.9.2 Test Mode Description

Pre-scan / Final test	Mode Code	Description
Final test	03	RX mode_Keep the EUT in receiving mode

6.9.3 Test Setup Diagram

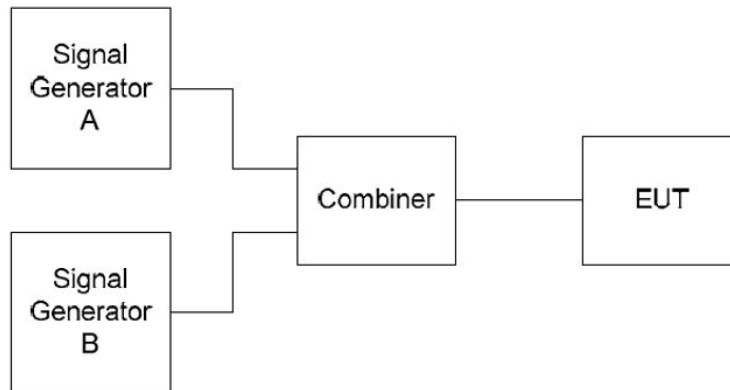

Figure 10: Blocking measurement arrangement



6.9.4 Measurement Procedure and Data

Signal generator A shall be set to an appropriate modulated test signal at the operating frequency of the EUT receiver.

Signal generator B shall be unmodulated.

Measurements shall be carried out at frequencies of the unwanted signal at approximately the frequency(ies) offset(s) defined in technical requirement avoiding those frequencies at which spurious responses occur. Additional

measurement points may be requested by technical requirements clause.

If several operational frequency bands are used by the equipment, at least one blocking measurement by bands has to be performed.

Step 1:

Signal generator B shall be powered off. Signal generator A shall be set to the minimum level which gives the wanted performance criterion of EUT or the reference level in Table 32, whichever is the higher. The output level of generator A shall then be increased by 3 dB unless otherwise specified in technical requirement.

Step 2:

Signal generator B is powered on and set to operate at the nominal operating frequency - offset frequency.

Signal generator B is then switched on and the signal amplitude is adjusted to the minimum level at which the wanted performance criterion is not achieved.

With signal generator B settings unchanged, the receiver shall be replaced with a suitable RF power measuring equipment. The power into the measuring equipment shall be measured and noted.

The blocking level is then the conducted power received from generator B at the EUT antenna connector.

This can either be measured on the antenna connector for conducted test or be calculated for radiated test (see clause C.5.4).

The blocking level shall be higher or equal to the blocking power level requested in the technical requirement clause.

Step 3:

The measurement in steps 1 to 3 shall be repeated with signal offsets at required frequencies.

Please Refer to Appendix for Details.



7 Test Setup Photo

Unwanted emissions in the spurious domain

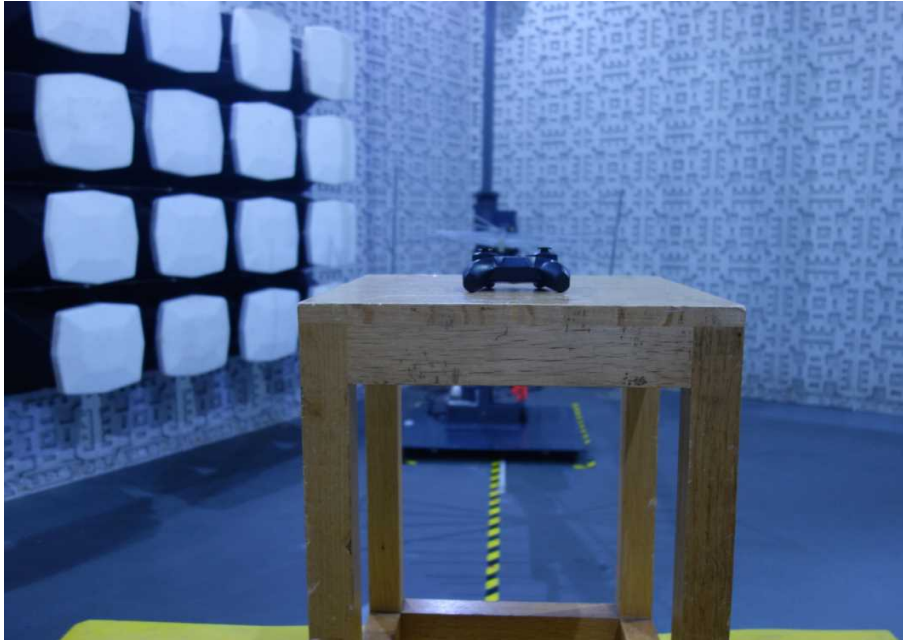

8 EUT Constructional Details (EUT Photos)

Refer to Appendix - Photographs of EUT Constructional Details for SZCR2304001176AT



Unless otherwise agreed in writing, this document is issued by the Company subject to its General Conditions of Service printed overleaf, available on request or accessible at <https://www.sgs.com/en/Terms-and-Conditions>. Attention is drawn to the limitation of liability, indemnification and jurisdiction issues defined therein. Any holder of this document is advised that information contained hereon reflects the Company's findings at the time of its intervention only and within the limits of Client's instructions, if any. The Company's sole responsibility is to its Client and this document does not exonerate parties to a transaction from exercising all their rights and obligations under the transaction documents. This document cannot be reproduced except in full, without prior written approval of the Company. Any unauthorized alteration, forgery or falsification of the content or appearance of this document is unlawful and offenders may be prosecuted to the fullest extent of the law. Unless otherwise stated the results shown in this test report refer only to the sample(s) tested and such sample(s) are retained for 30 days only.

Attention: To check the authenticity of testing /inspection report & certificate, please contact us at telephone: (86-755) 8307 1443, or email: CN.Doccheck@sgs.com

No.1 Workshop, M-10, Middle Section, Science & Technology Park, Nanshan District, Shenzhen, Guangdong, China 518057 t (86-755) 26012053 f (86-755) 26710594 www.sgs.com.cn
中国·广东·深圳市南山区科技园中区M-10栋1号厂房 邮编: 518057 t (86-755) 26012053 f (86-755) 26710594 sgs.china@sgs.com

9 Appendix

1. Operating frequency

Test Data:

Measurement Conditions		Operating frequency	Nominal Operating Frequency	OCW	Limit (dBm)	Result
T _{normal} (24°C)	V _{norm} : 3.0V dc	27.1453MHz	27.145MHz	18.5kHz	26.957 MHz to 27.283MHz	PASS

2. Effective Radiated Power

Test Data:

Measurement Conditions	Operation Frequency	ERP	Limit	Result
TNVN	27.1453MHz	-29.90dBm	10mW (i.e. 10 dBm)	PASS
TLVL	27.1451MHz	-30.56dBm	10mW (i.e. 10 dBm)	PASS
TLVH	27.1452MHz	-29.21dBm	10mW (i.e. 10 dBm)	PASS
THVL	27.1452MHz	-30.80dBm	10mW (i.e. 10 dBm)	PASS
THVH	27.1453MHz	-30.42dBm	10mW (i.e. 10 dBm)	PASS



Unless otherwise agreed in writing, this document is issued by the Company subject to its General Conditions of Service printed overleaf, available on request or accessible at <https://www.sgs.com/en/Terms-and-Conditions>. Attention is drawn to the limitation of liability, indemnification and jurisdiction issues defined therein. Any holder of this document is advised that information contained hereon reflects the Company's findings at the time of its intervention only and within the limits of Client's instructions, if any. The Company's sole responsibility is to its Client and this document does not exonerate parties to a transaction from exercising all their rights and obligations under the transaction documents. This document cannot be reproduced except in full, without prior written approval of the Company. Any unauthorized alteration, forgery or falsification of the content or appearance of this document is unlawful and offenders may be prosecuted to the fullest extent of the law. Unless otherwise stated the results shown in this test report refer only to the sample(s) tested and such sample(s) are retained for 30 days only.

Attention: To check the authenticity of testing /inspection report & certificate, please contact us at telephone: (86-755) 8307 1443, or email: CN.Doccheck@sgs.com

No.1 Workshop, M-10, Middle Section, Science & Technology Park, Nanshan District, Shenzhen, Guangdong, China 518057 t (86-755) 26012053 f (86-755) 26710594 www.sgsgroup.com.cn
 中国·广东·深圳市南山区科技园中区M-10栋1号厂房 邮编: 518057 t (86-755) 26012053 f (86-755) 26710594 sgs.china@sgs.com

3. Occupied Bandwidth

Test Data:

Measurement Conditions	Operating frequency	OBW	Limit	Result
TNVN	27.1453MHz	18.3kHz	25 kHz	PASS
TLVL	27.1451MHz	18.2kHz	25 kHz	PASS
TLVH	27.1452MHz	18.2kHz	25 kHz	PASS
THVL	27.1452MHz	18.1kHz	25 kHz	PASS
THVH	27.1453MHz	18.2kHz	25 kHz	PASS



Unless otherwise agreed in writing, this document is issued by the Company subject to its General Conditions of Service printed overleaf, available on request or accessible at <https://www.sgs.com/en/Terms-and-Conditions>. Attention is drawn to the limitation of liability, indemnification and jurisdiction issues defined therein. Any holder of this document is advised that information contained hereon reflects the Company's findings at the time of its intervention only and within the limits of Client's instructions, if any. The Company's sole responsibility is to its Client and this document does not exonerate parties to a transaction from exercising all their rights and obligations under the transaction documents. This document cannot be reproduced except in full, without prior written approval of the Company. Any unauthorized alteration, forgery or falsification of the content or appearance of this document is unlawful and offenders may be prosecuted to the fullest extent of the law. Unless otherwise stated the results shown in this test report refer only to the sample(s) tested and such sample(s) are retained for 30 days only.

Attention: To check the authenticity of testing /inspection report & certificate, please contact us at telephone: (86-755) 8307 1443, or email: CN.Doccheck@sgs.com

No.1 Workshop, M-10, Middle Section, Science & Technology Park, Nanshan District, Shenzhen, Guangdong, China 518057 t (86-755) 26012053 f (86-755) 26710594 www.sgs.com.cn
 中国·广东·深圳市南山区科技园中区M-10栋1号厂房 邮编: 518057 t (86-755) 26012053 f (86-755) 26710594 sgs.china@sgs.com

4. Transient Power

Test Data:

Measurement points: offset from centre frequency	Transient Power (dBm) REF	Limit(dBm)	Result
-0,5 x OCW - 3 kHz 0,5 x OCW + 3 kHz Not applicable for OCW < 25 kHz	N/A	0	N/A
-12,5 kHz or -OCW whichever is the greater	-51.5	0	PASS
12,5 kHz or OCW whichever is the greater	-51.3	0	PASS
-0,5 x OCW - 400 kHz	-82.6	-27	PASS
0,5 x OCW + 400 kHz	-83.1	-27	PASS
-0,5 x OCW -1 200 kHz	-98.9	-27	PASS
0,5 x OCW + 1 200 kHz	-98.6	-27	PASS
Remark: OCW is 18.5kHz per the result of sub clause 9.1.1			



Unless otherwise agreed in writing, this document is issued by the Company subject to its General Conditions of Service printed overleaf, available on request or accessible at <https://www.sgs.com/en/Terms-and-Conditions>. Attention is drawn to the limitation of liability, indemnification and jurisdiction issues defined therein. Any holder of this document is advised that information contained hereon reflects the Company's findings at the time of its intervention only and within the limits of Client's instructions, if any. The Company's sole responsibility is to its Client and this document does not exonerate parties to a transaction from exercising all their rights and obligations under the transaction documents. This document cannot be reproduced except in full, without prior written approval of the Company. Any unauthorized alteration, forgery or falsification of the content or appearance of this document is unlawful and offenders may be prosecuted to the fullest extent of the law. Unless otherwise stated the results shown in this test report refer only to the sample(s) tested and such sample(s) are retained for 30 days only.

Attention: To check the authenticity of testing /inspection report & certificate, please contact us at telephone: (86-755) 8307 1443, or email: CN.Doccheck@sgs.com

No.1 Workshop, M-10, Middle Section, Science & Technology Park, Nanshan District, Shenzhen, Guangdong, China 518057 t (86-755) 26012053 f (86-755) 26710594 www.sgs.com.cn
 中国·广东·深圳市南山区科技园中区M-10栋1号厂房 邮编: 518057 t (86-755) 26012053 f (86-755) 26710594 sgs.china@sgs.com

5. Adjacent Channel Power

Test Data:

Measurement Conditions (in Normal & Extreme)		Adjacent channel	ACP Measured (dBm)	Limit (dBm)	Result
T _{normal} (24°C)	V _{norm} : 3.0V dc	+adjacent channel	-38.49	-20 (10μW)	PASS
		-adjacent channel	-38.68		
T _{upper} (+45°C) after Tx on for 30 minutes	V _{max} : 3.0V dc	+adjacent channel	-40.16	-15 (32μW)	PASS
		-adjacent channel	-40.44		
	V _{min} : 2.55V dc	+adjacent channel	-41.35	-15 (32μW)	PASS
		-adjacent channel	-41.65		
T _{lower} (0°C) after Tx on for 1 minute	V _{max} : 3.0V dc	+adjacent channel	-37.26	-15 (32μW)	PASS
		-adjacent channel	-37.41		
	V _{min} : 2.55V dc	+adjacent channel	-38.13	-15 (32μW)	PASS
		-adjacent channel	-38.36		

Measurement Conditions (in Normal & Extreme)		Alternate channel	ACP Measured (dBm)	Limit (dBm)	Result
T _{normal} (24°C)	V _{norm} : 3.0V dc	+alternate channel	-40.65	-20 (10μW)	PASS
		-alternate channel	-40.51		
T _{upper} (+45°C) after Tx on for 30 minutes	V _{max} : 3.0V dc	+alternate channel	-42.85	-20 (10μW)	PASS
		-alternate channel	-42.71		
	V _{min} : 2.55V dc	+alternate channel	-44.03	-20 (10μW)	PASS
		-alternate channel	-43.81		
T _{lower} (0°C) after Tx on for 1 minute	V _{max} : 3.0V dc	+alternate channel	-39.69	-20 (10μW)	PASS
		-alternate channel	-39.25		
	V _{min} : 2.55V dc	+alternate channel	-40.59	-20 (10μW)	PASS
		-alternate channel	-40.00		



Unless otherwise agreed in writing, this document is issued by the Company subject to its General Conditions of Service printed overleaf, available on request or accessible at <https://www.sgs.com/en/Terms-and-Conditions>. Attention is drawn to the limitation of liability, indemnification and jurisdiction issues defined therein. Any holder of this document is advised that information contained hereon reflects the Company's findings at the time of its intervention only and within the limits of Client's instructions, if any. The Company's sole responsibility is to its Client and this document does not exonerate parties to a transaction from exercising all their rights and obligations under the transaction documents. This document cannot be reproduced except in full, without prior written approval of the Company. Any unauthorized alteration, forgery or falsification of the content or appearance of this document is unlawful and offenders may be prosecuted to the fullest extent of the law. Unless otherwise stated the results shown in this test report refer only to the sample(s) tested and such sample(s) are retained for 30 days only.

Attention: To check the authenticity of testing /inspection report & certificate, please contact us at telephone: (86-755) 8307 1443, or email: CN.Doccheck@sgs.com

No.1 Workshop, M-10, Middle Section, Science & Technology Park, Nanshan District, Shenzhen, Guangdong, China 518057 t (86-755) 26012053 f (86-755) 26710594 www.sgs.com.cn
 中国·广东·深圳市南山区科技园中区M-10栋1号厂房 邮编: 518057 t (86-755) 26012053 f (86-755) 26710594 sgs.china@sgs.com

6. TX behaviour under Low Voltage Conditions

Test Data:

Nominal Frequency was: 27.145 MHz

Test Voltage (V)	Test result (MHz)	Test result (output power for relative value)	Limit	Result
V _{norm} : 3.0V dc	27.1453	-29.90dBm(REF)	26.957-27.283MHz	PASS
V _{ext} : 2.55V dc	27.1451	-36.25dBm	26.957-27.283MHz	PASS
V _{ext} : 1.5V dc	27.1448	-39.68dBm	26.957-27.283MHz	PASS
V _{lowest} : 0.7V dc		cease function		PASS

Remark:

- 1) No other exceeding any applicable limits were found during the tests
- 2) Applied test voltage: reduced from 3V to 0V DC

7. Blocking Test Data:

Receiver Category	Frequency Offset	Value(dBm)	Limit(dBm)	Result
2	+2MHz	-40.65	-69	Pass
2	-2MHz	-41.02	-69	Pass
2	+10MHz	-35.43	-44	Pass
2	-10MHz	-35.09	-44	Pass
2	+15MHz	-25.61	-44	Pass
2	-15MHz	-25.47	-44	Pass

- End of the Report -

